

# UMPETHA

SLIDING GATE MOTOR

Domestic sliding gate operator by ET SYSTEMS.



**Installer instructions**



<b>Table of contents</b>	
<b>Page</b>	<b>Category</b>
<b>Introduction</b>	
3	Safety obligations and general warnings
4	Identification of components
5	Technical specifications
6	Before installing preparation
7	Cable requirements
<b>Hardware installation</b>	
8	Accessing manual override and removing cover
9	Installing the baseplate and positioning motor
10	Inserting or removing battery and mounting of motor to baseplate
11	Installing the rack
13	Installing the limit actuator
14	Control card wiring layout
<b>Motor control programming</b>	
15	Run time set-up
16	Auto-close time programming
17	Pedestrian opening and pedestrian auto-close time programming
18	Changing the crawl distance
19	Changing the switch type input for the beams
20	Adjusting the safety sensing level
<b>Receiver programming</b>	
21	Master erase
22	Registering a transmitter using the receiver pins
23	Registering a transmitter using the master remote transmitter
<b>Operating mode selection</b>	
24	Standard mode
24	Simple auto-close mode
24	Complex auto-close/Condominium mode
25	P.I.R.A.C. mode
<b>Additional features</b>	
26	Holiday lock-out
26	Beam Alarm Output (B.A.O)
27	Auto-close override/party mode
27	Pedestrian operation
27	Courtesy light functionality
<b>Trouble shooting</b>	
28	Buzzer indication trouble shooting guide
28	Status LED indication guide
29	<b>Warranty</b>

**WARNING TO THE INSTALLER. GENERAL SAFETY OBLIGATIONS.**

- Caution! It is important for personal safety to follow all the instructions carefully. Incorrect installation or misuse may cause serious personal harm.
- Keep the instructions in a safe place for future reference.
- This product was designed and manufactured strictly for the use indicated in this documentation. Any other use not expressly indicated in this documentation, may damage the product and/or be a source of danger.
- We accept no responsibility due to improper use of this product.
- Care must be taken not to install this product in an unsafe environment. I.e. near inflammable gases and or fumes.
- We will not accept responsibility if the principles of good workmanship are disregarded by the installer. The construction of the gate must be sound and automatable. It is the responsibility of the installer to ensure that all mountings to the gate are sufficient to withstand the necessary forces in cases of overload.
- Before carrying out any work on the product, ensure that the electrical supply is switched off.
- It is highly recommended that a set of safety infra-red beams be used in conjunction with this product.
- We accept no responsibility regarding safety and correct operation of the automation if other manufacturer's equipment is added to this product.
- Do not make any modifications or alterations to this product.
- It is the responsibility of the installer/ service provider to completely instruct and demonstrate the proper use of this product, especially the emergency override, to the end user. It is also the responsibility of the installer/ service provider to issue all end user documentation, which accompanies this product, to the end user.
- Ensure that other persons, especially children are clear of the gate and opener before and during operation.
- Keep remote transmitters away from children to prevent accidental activation of the system.
- The end user should refrain from attempting to make any repairs or adjustments to the system and should contact professional qualified assistance timorously.
- Anything other than expressly provided for in these instructions is not permitted.
- The electrical supply to this product must comply with the local electrical code of practice and any electrical work must be carried out by a qualified electrician.
- Over and above the recommendation to use safety infra-red beams with this product it is mandatory to ensure a set has been installed and is in proper working condition when using the automatic closing feature.

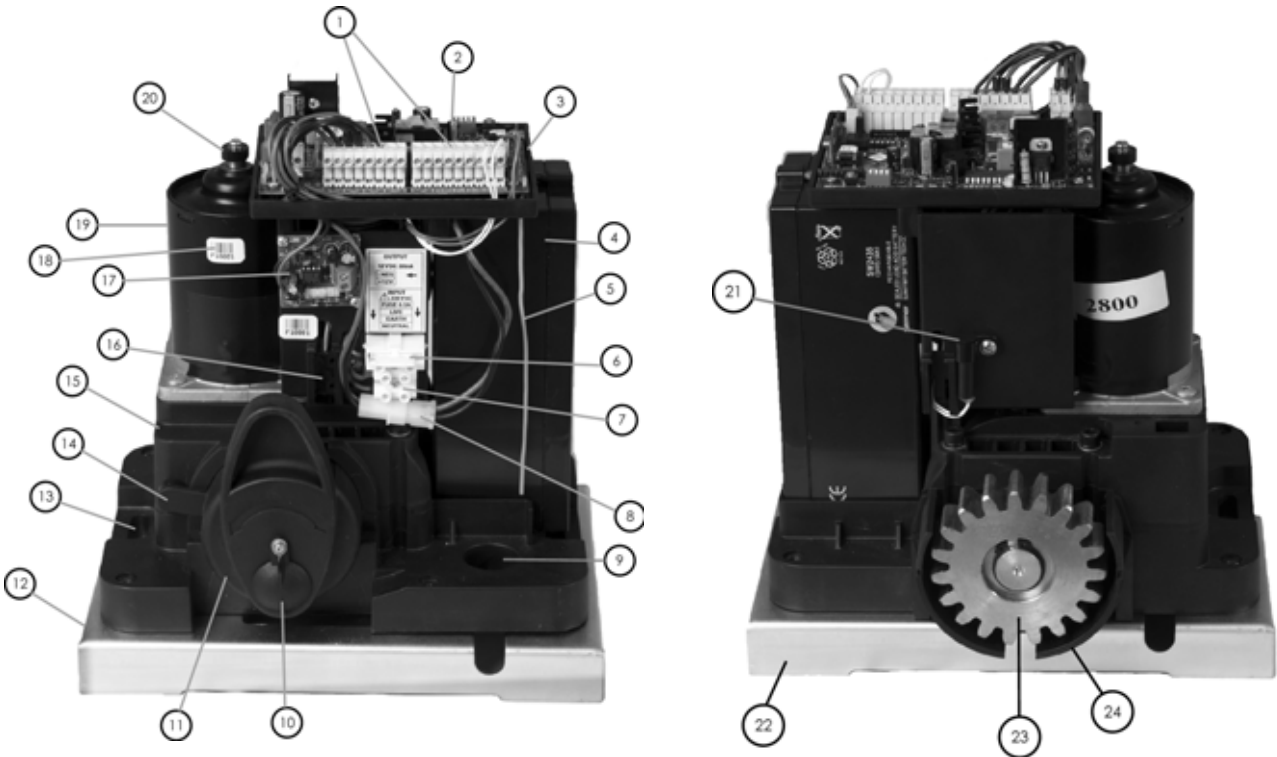

1. Plug in terminal connectors	13. Motor mounting slot
2. Control card	14. Manual override cam sensor magnet
3. Control card holder	15. Gearbox housing
4. Battery	16. Manual override cam reed switch sensor
5. Antenna	17. DC to DC switch-mode 12V Aux supply module (300mA peak)
6. 220Vac 500mA fast blow fuse for primary supply*	18. Serial number
7. 220Vac 15A fixed terminal connections*	19. 24Vdc Fixed magnet motor
8. Inline unidirectional battery plug (polarised)	20. Revolution counter magnet
9. Cable entry point	21. Closed limit reed switch sensor
10. Manual override lock with protection flap	22. Base plate
11. Manual override cam	23. Pinion gear
12. Base plate	24. Pinion gear protection flange

\*For built in transformer model.

**TECHNICAL SPECIFICATIONS**

POWER SUPPLY @ GATE REQUIREMENT	29Vac 1Amp plug-in transformer model 220Vac for built in transformer model
MAXIMUM ABSORBED CURRENT @ 220V AC SUPPLY	100mA
MOTOR VOLTAGE	24Vdc
MAXIMUM STARTING RESISTANCE OF GATE	< 10kgF set
MAXIMUM RUNNING RESISTANCE OF GATE	< 6kgF set
GATE SPEED	16m/min @ maximum rated gate resistance
DUTY CYCLE	4 operations per hour*
OPERATING TEMPERATURE RANGE	-10 / +50° C
ANTI-CRUSHING SAFETY SENSING	ELECTRONIC
NETT. WEIGHT	10.70kg
MAXIMUM GATE LENGTH	6m
MAXIMUM GATE MASS	300kg
AUXILIARY OUTPUT FOR ANCILLIARIES	12Vdc at 300mA
RATED BATTERY CHARGING VOLTAGE	27.2Vdc

\* Calculation based on a gate leaf  $\leq$  maximum length with a rolling resistance of  $\leq$  maximum rated gate resistance.

**BEFORE ATTEMPTING TO INSTALL A SLIDE GATE OPERATOR, PLEASE BE CERTAIN YOU HAVE READ AND UNDERSTOOD THE FOLLOWING TO ENSURE CONTINUED SATISFACTORY SAFE SERVICE FROM THIS PRODUCT:**

The following are points to note before installing your new slide gate operator:

1. Gate mechanics
2. Cabling requirements

1. **GATE MECHANICS**

a) Gate Leaf

Gate leaf must be sound and of sufficient construction to accommodate an operator of this type (see technical specifications). Gate leaf should be straight and true with minimal deviation to the fascia that the rack must attach to (no 'banana-effect').

b) Wheels and track

The track must be **secure, straight, level** and free of all obstructions.

Recommended wheel type and size for this automation is steel or steel alloy, machined or cast wheels of at least **100mm diameter** using sealed roller bearings. The larger the wheel the less rolling resistance generated. Larger wheels also maintain their plumb and momentum longer. When wheels are fixed in the gate, and not able to pivot, binding can occur if the gate is bowed (banana effect) For wheel profile and matching track types, see the three examples below:

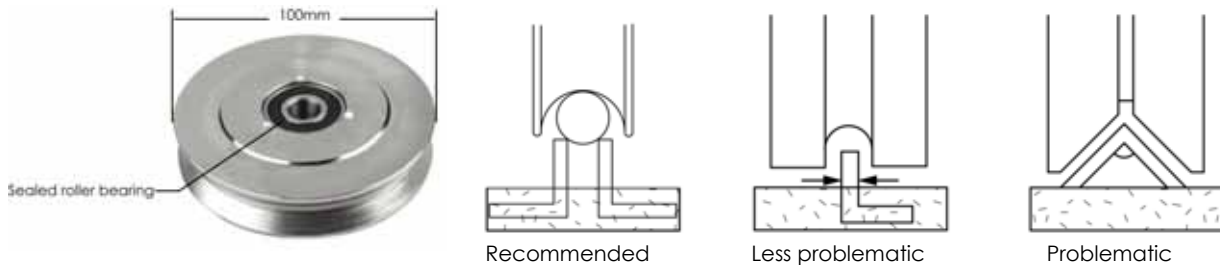

c) Guides

- It is recommended that a roller guide consisting of a sealed roller bearing clad in nylon be used.
- The guidance system should be installed at the top edge of the gate whenever possible. In cases where this is not possible the guidance system should never be below the halfway point of the total gate height when the gate is in position on its track.
- In the case of a single guide roller running in a guide channel, ensure the guide never touches both inside walls of the channel simultaneously. This causes the roller to snag as it tries to roll in both directions at once.
- In the case of 2 guide rollers being used on either side of the gate leaf, ensure that both wheels never touch the leaf simultaneously.
- Avoid using more than 1 guide roller on the same side of the gate leaf to prevent binding.
- As with the wheels the larger the guide the less rolling resistance generated.

d) Gate Travel

Using a fish-scale, as shown below, pull the gate fully open and fully closed at approximately the same speed as the operator you intend to use (see technical specifications). For optimum duty cycle, ensure that the maximum resistance does not exceed 10kgF starting and 6kgF running. The starting resistance should fall away within 300 to 500mm. Note the recommended track, wheel and guide types mentioned b) and c) above.

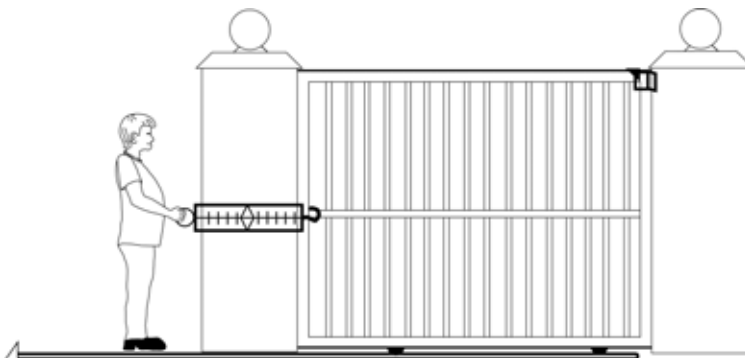

**NB!** Install physical stoppers at the ends of the gate travel to avoid the gate over-running the ends of the track - as shown here. (National safety standard requirement)

**CABLING REQUIREMENTS**

Before mounting the operator ensure your cabling and conduiting are in place to prevent any inconvenience at a later stage. Allow for spare cabling in case of faulty cable & breakages (especially important when using low specification cable). If installing an intercom, remember to allow for sufficient cable cores for all the uses on the system as per manufacturers cabling requirements.

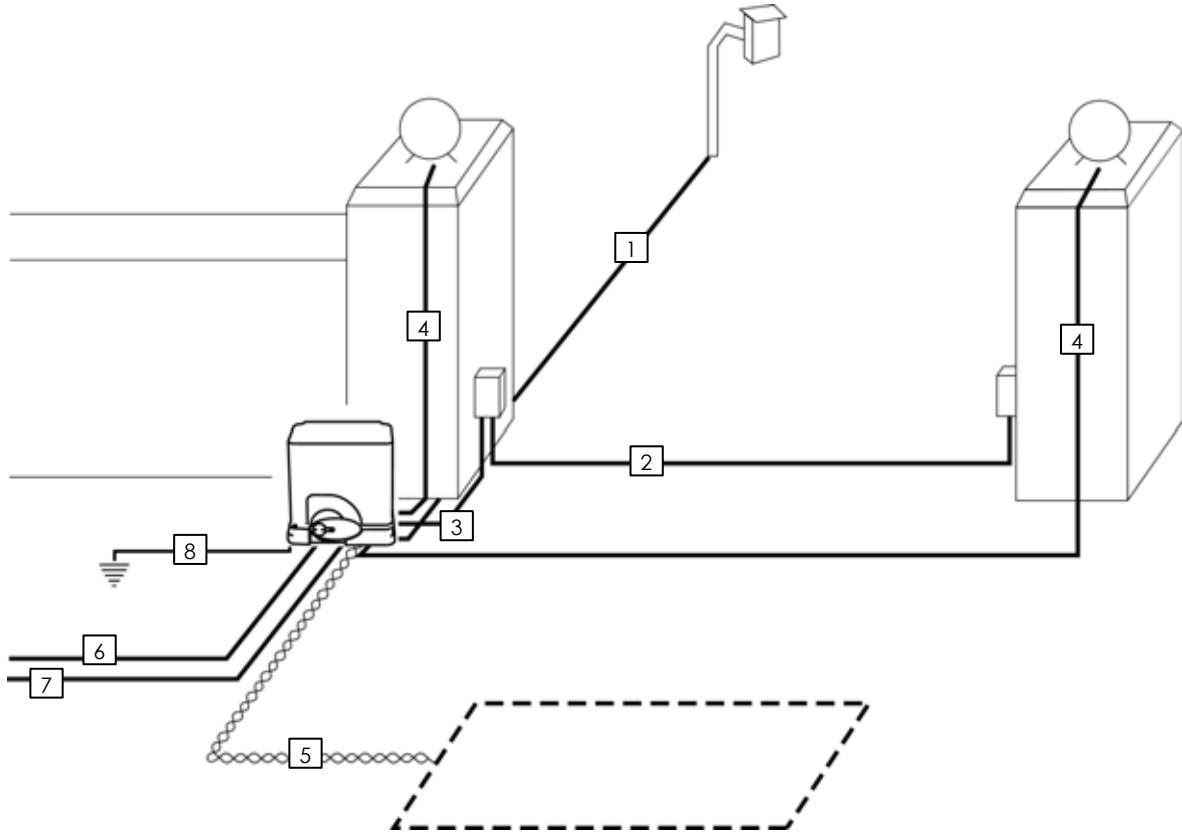

1. Intercom gate station (check with intercom supplier specifications)	5. Free exit loop (1.5mm silicone insulated single core flexible stranded)
2. Safety infra-red beam power (2-core)	6. Primary power: Plug in transformer model - twin: min 0,5mm Internal in-line transformer model (220Vac) - twin + earth: 1,0mm
3. Safety infra-red beam power & switch (4-core)	7. From intercom internal equipment (check with intercom supplier specifications)
4. Courtesy lights (twin + earth 1.0mm)	8. Optional earth-rod for high lightning strike areas (preferably use household earth leakage)

**Manually overriding the gearbox and removing the cover**



Locked and engaged



Unlocked and engaged  
Insert key and turn  
clockwise.



Unlocked and  
disengaged

Remember to pull or push the gate gently until the gears "click" re-engage, before running the motor after a manual override. When the override cam is in the manual override position the electronic control is disabled. To operate the control card the cam must be in the engaged position.



Cover housing screw  
beneath manual  
override cam



Second cover screw



Third cover screw



Fourth cover screw



**Motor positioning to gate.**

Hot tip: Cast the track plinth at the same time as the motor plinth

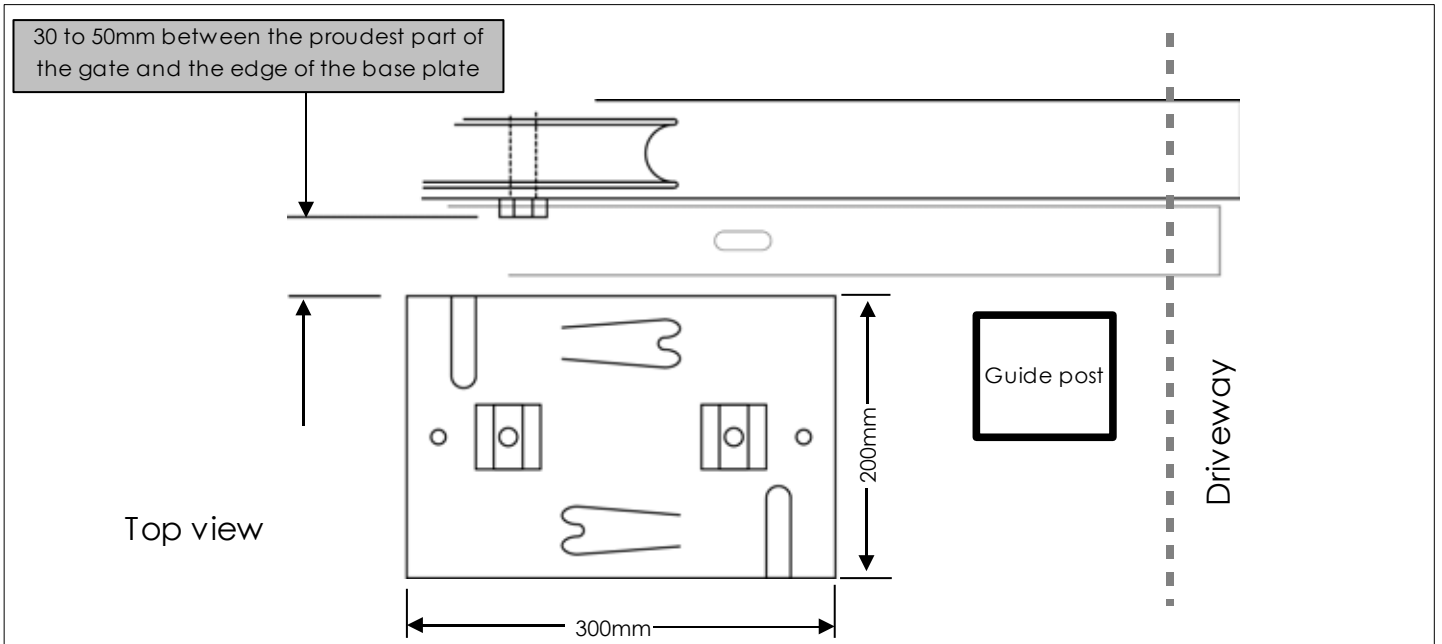

Install the base plate on the protected side of the driveway wherever possible. (opposite side of the guide post to the driveway) The base plate must be installed 30 to 50mm away from the proudest part of the gate. The wheel bolt is the proudest part of the gate here. If in doubt rather install the base plate further away and use spacers between the gate fascia and the rack when installing the rack.

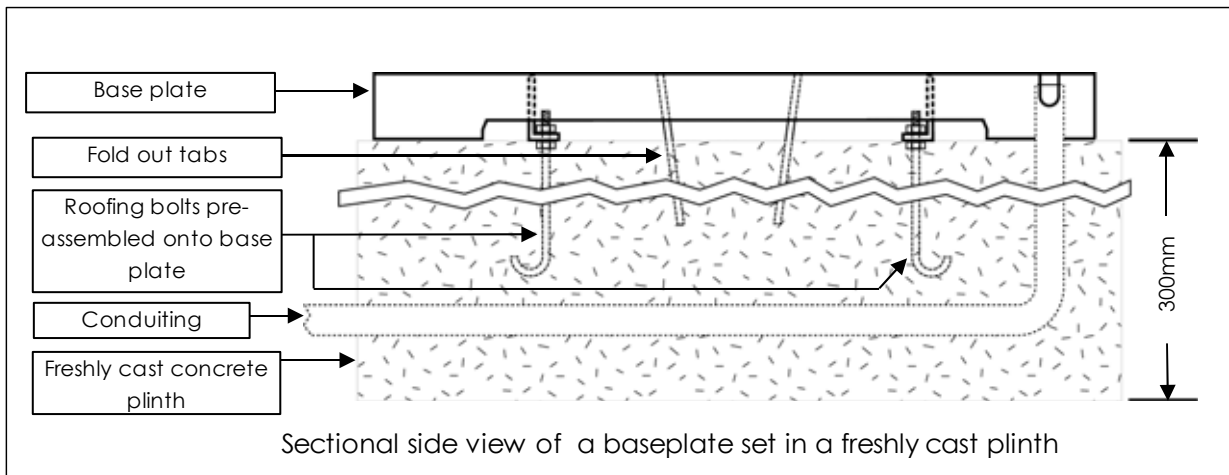
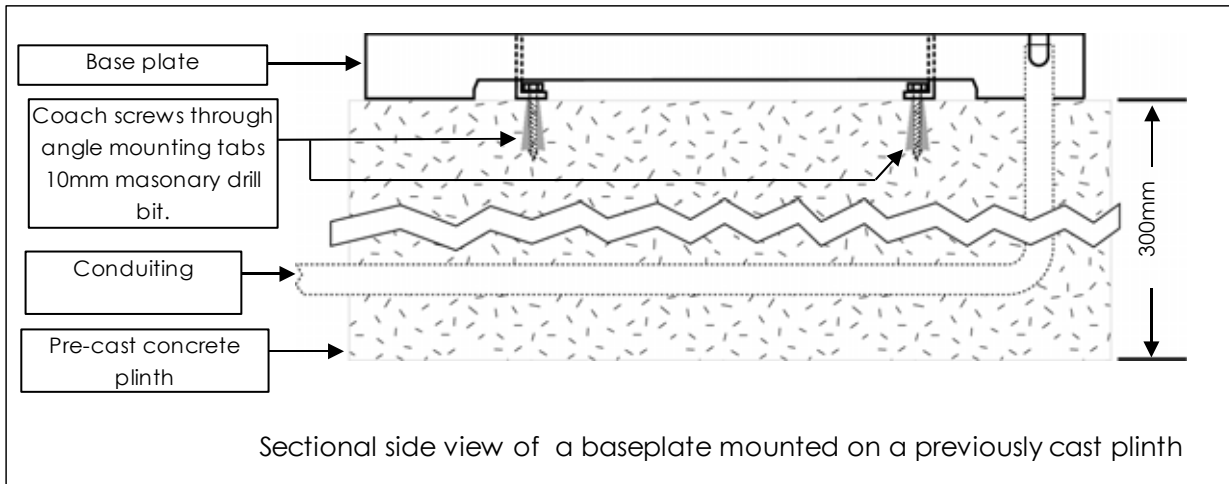

**Inserting and removing the battery**

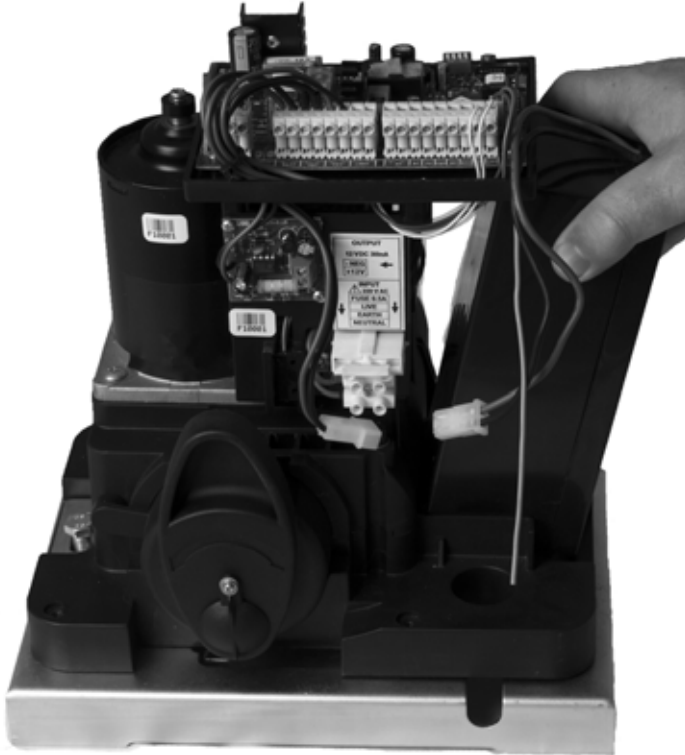

**Please note!** In the cases where something like the gate guide post or a wall is obstructing the battery from being angled to one side, making it impossible to insert or remove the battery then carefully remove the control card and control card holder before removing the battery.

**Remember to ensure the control card and holder are both secured in place correctly when finished.**

**Fastening the operator to the base plate**

Fasten motor to the base plate using the bolts and plates from the top as shown here

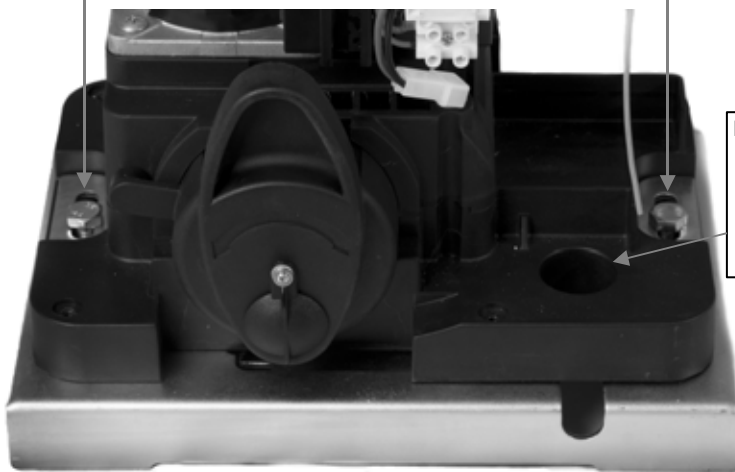

Be careful that the cables are not trapped and damaged when fastening or adjusting the motor on the base plate

**Installing the rack.**



**Rack to pinion spacing. Correct.**

The driving surfaces of each tooth are 1 to 2mm apart. Allowing for slight variance in the height of the rack when the wheels shrink in colder conditions or where the gate flexes and the rack is no longer square to the pinion.



**Rack to pinion spacing. Space to large.**

This will cause skipping at the slightest resistance to the gate travel, resulting in the motor control going out of synchronisation to the gate position. (Losing open limit) The long term damage here will be stripped teeth.



**Rack to pinion spacing. To tight.**

This will cause unwanted rolling resistance especially in colder conditions. Where the wheel shrinkage will cause the gate to sit heavier on the pinion or the rack is no longer square to the pinion due to gate flex. (False safety sensing activation)

Begin by fastening the motor atop the base plate with 2mm spacer plates between.

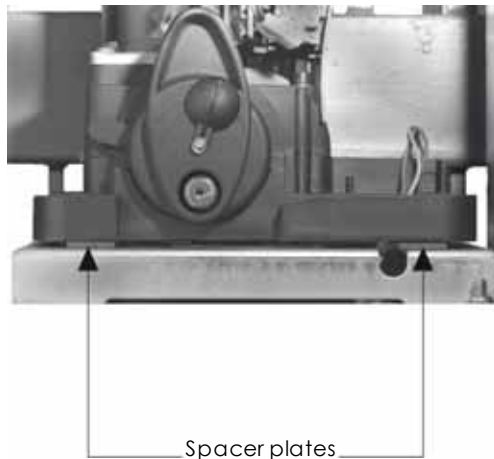

Clamp the end of the first length of rack end to the closing edge of the gate. Rest the other end of the length on the pinion as shown here. Use a spirit level to ensure the rack remains true.

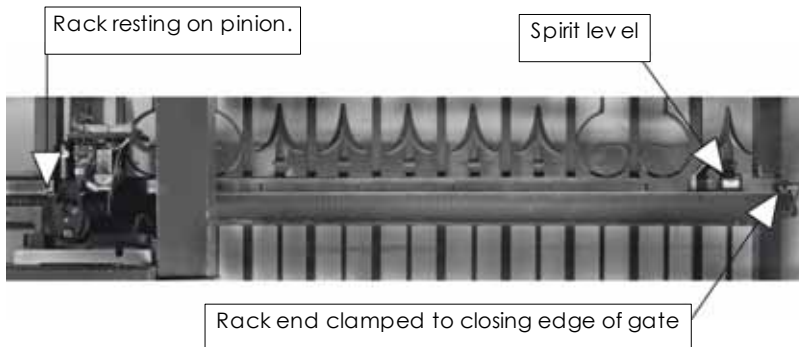

If satisfied with the rack level fasten the first "TEK" screw (supplied) in the middle of the slot nearest the closing edge of the gate.



Move the gate towards the open position. Far enough that you can access the last mounting slot at the opposite end of the length of rack to the end already fastened. Fasten the next "TEK" screw here while the rack still rests atop the pinion.



To install additional lengths of rack, move gate closed until the next length of rack meets the first length and the opposite end once again rests on the pinion. To ensure the 2 lengths of rack marry correctly use an off cut of rack clamped upside down across the join of the 2 lengths. Continue to fasten the "TEK" screws as before.

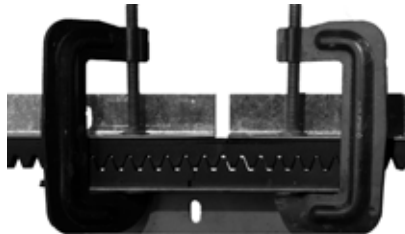

When finished installing sufficient rack to allow for the full travel of the gate plus enough to allow for the limit actuator (as shown in the next section) remove the spacer plates and test the meshing of the rack and pinion. (See above pictures of rack spacing). If satisfied fasten a "TEK" screw directly through both the rack angle and the gate so that you have 5 "TEK" screws per length of rack evenly spaced.



**Installing the limit actuator**  
 (Mandatory before programming)

1. Push the gate up against the closed stopper/keep.
2. Place magnetic actuator on top of the rack where it is half way across the reed switch. See below
3. Remove the rack screw (Holding the nylon teeth to the steel angle) closest to the middle of the slot in the actuator.
4. Replace this screw with the longer screw provided with the actuator.
5. Adjust the stopping position by sliding the actuator sideways. Check the closed limit LED while doing this.

After programming the run-time (page 15) the gate should stop a minimum of 10-20mm from the mechanical end stop. Adjust the actuator if necessary.

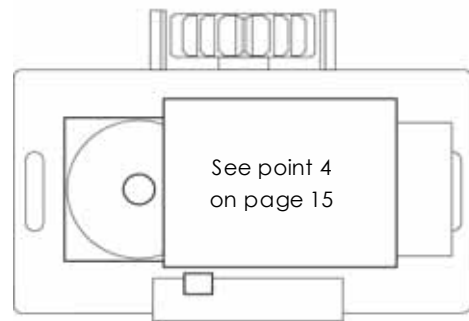
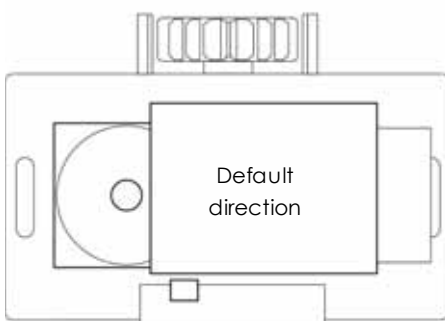
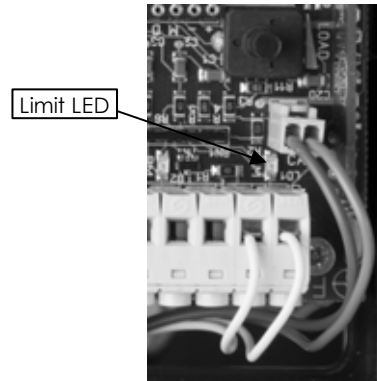
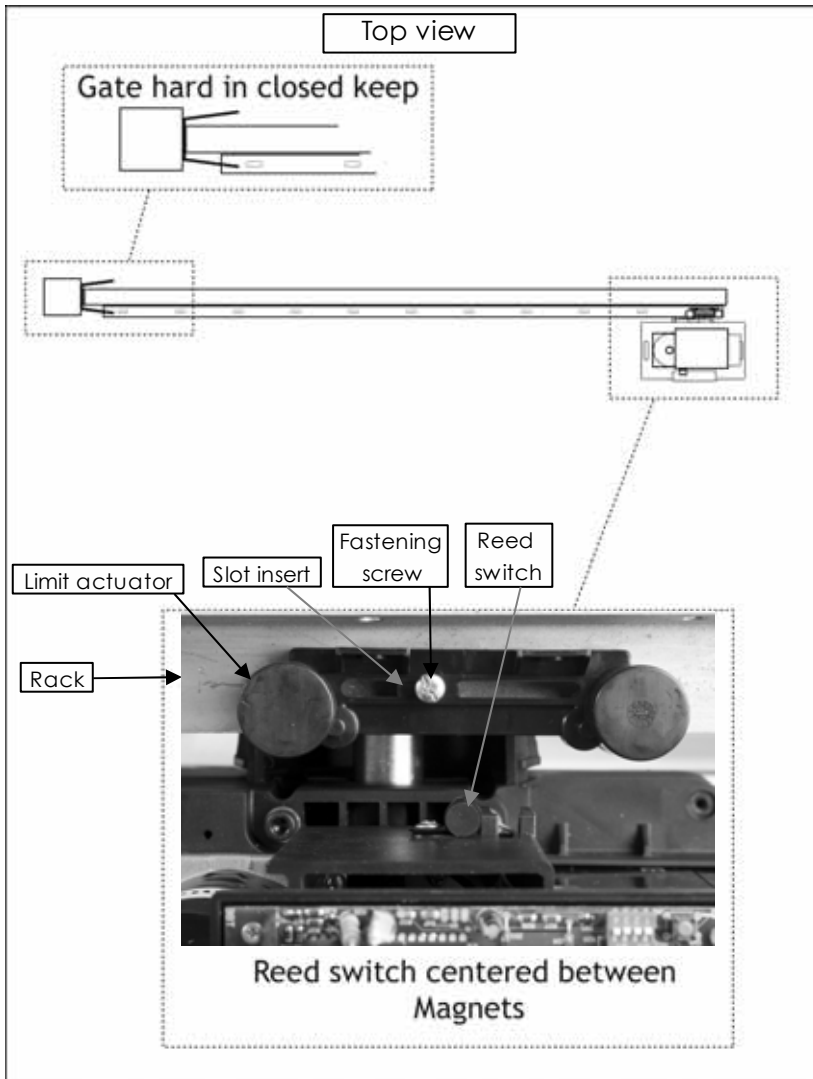



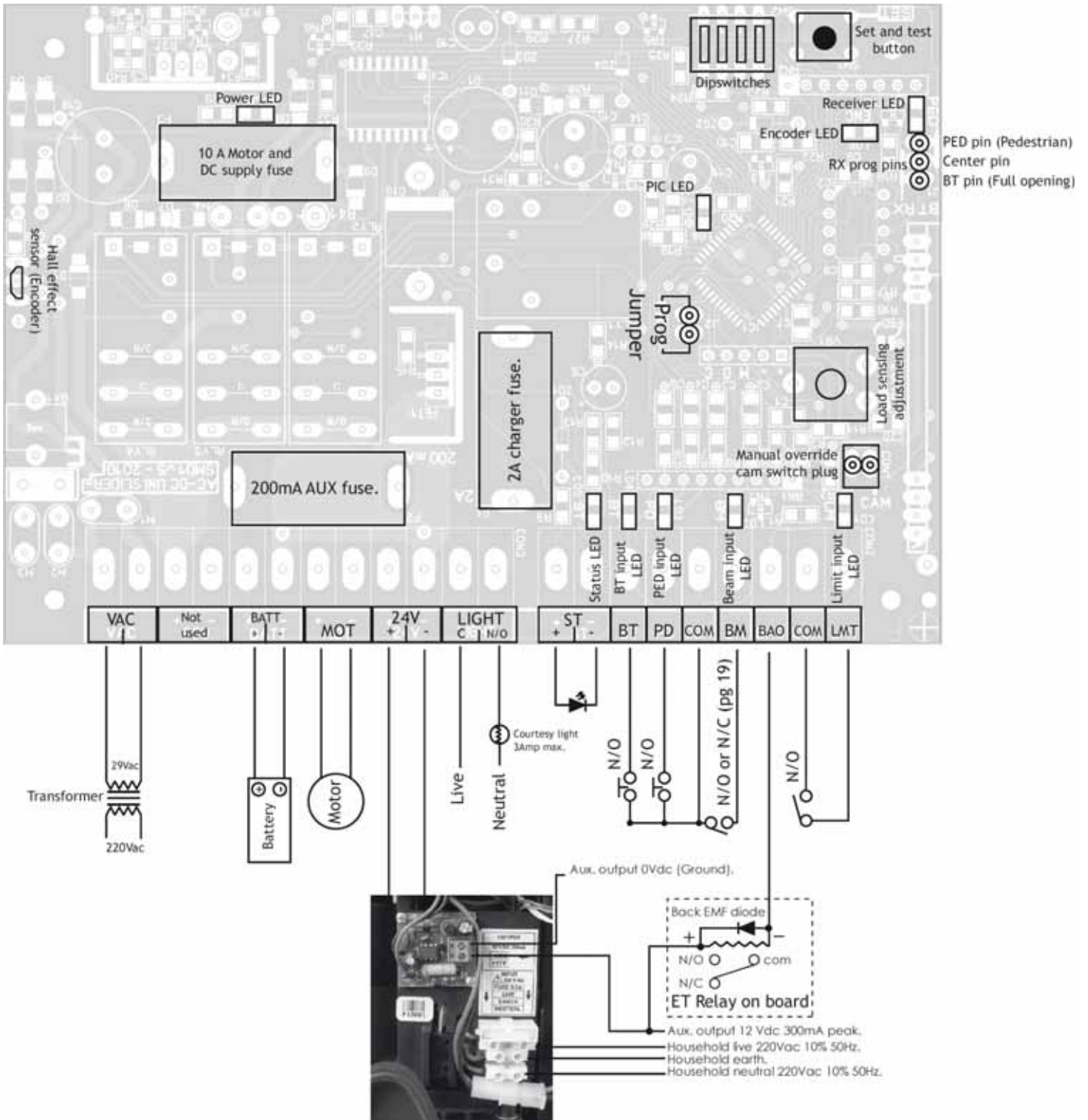

Control card layout and wiring.

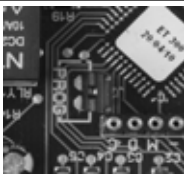
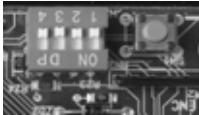
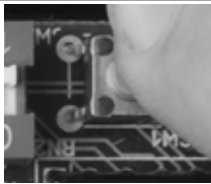
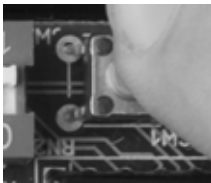

**Runtime Setup**

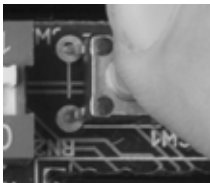
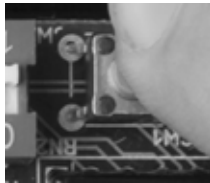
**The run- time routine must be completed before attempting to continue with any other routine! The closed limit actuator must be installed correctly before starting this routine!**

Action		Response
1. Gate midway and engaged.		
2. Program jumper on		2 beeps
3. All dip-switches off.		
4. Press and release Set button		Gate must close. <b>If gate opens first press and release set button then see A below!</b>
5. At closed limit		Gate starts opening
6. Press and release Set button at required full open position ( $\pm 25\text{mm}$ short of physical stopper)		Gate stops and closes
7. At closed position		1 beep
Remove program jumper or continue to next feature		
<b>*** Changing gate direction if it opens first above.</b>		
<b>A)</b> On pressing and releasing the set button while gate was opening first		Gate stops, 1 beep
<b>B)</b> Dip-switch 3 on		
<b>C)</b> Press and release Set button		Gate will now close correctly
<b>D)</b> At closed limit		Gate starts opening
<b>E)</b> Press and release Set button at required full open position ( $\pm 25\text{mm}$ short of physical stopper)		Gate stops and closes
<b>F)</b> At closed position		1 beep, pause, continuous beep.
<b>G)</b> Dip-switch 3 off		Continuous beep off
Remove program jumper or continue to another programming option		

**Auto-close time:-**



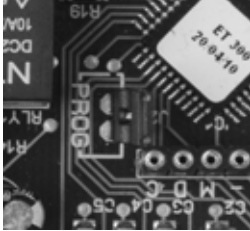
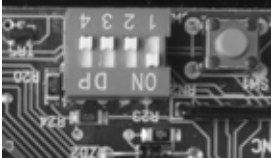
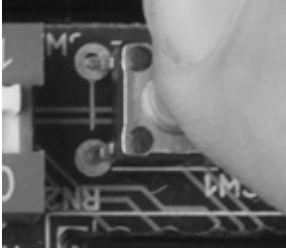
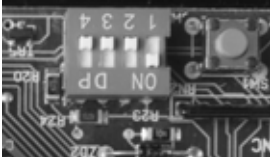
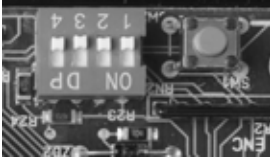

(Default = 15sec.)

**NB! The auto-close mode type must be selected after all programming is completed.**

(See operating mode selection on page 24)

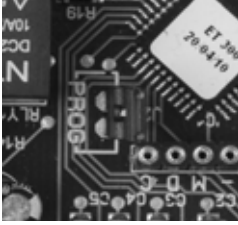
Action		Response
1. Program jumper on		2 beeps
2. Dip-switch 1 on		
3. Press and hold Set button, count beeps for required auto-close time.		1 beep = 1sec. 2 beeps = 2sec. ....cont 255 beeps = 4.25 min. (Max)
4. Release Set button at required auto-close time		Continuous beep
5. Dip-switch 1 off		Continuous beep stops
To change the time again without leaving programming, repeat from point 2.		
Remove program jumper or continue to another programming option.		
<b>NB! This does not activate the Auto-close function. For this see selecting operating modes on page 24</b>		

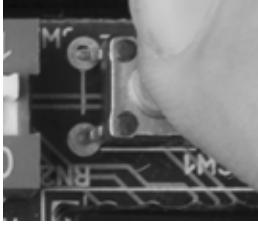
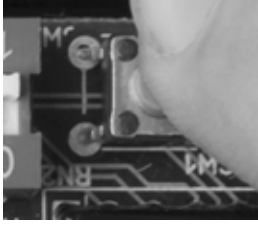
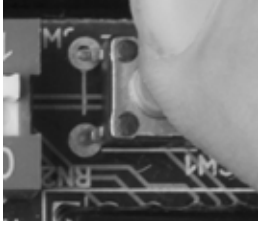

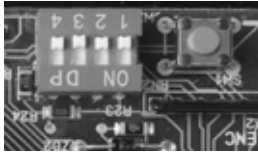
Pedestrian opening distance and independent pedestrian auto-close time:-		
(Default = ± 1m opening and 5sec. auto-close time)		
Action		Response
Gate midway and engaged		
1. Program jumper on		2 beeps
2. Dip-switch 2 on		
3. Press and release Set button		Gate closes
4. At closed position		Gate opens
5. Press and release Set button at required open distance		Gate stops
6. Press and hold Set button, count beeps for auto-close time.		1 beep = 1sec. 2 beeps = 2sec. ....cont 255 beeps = 4.25 min. (Max)
7. Release Set button at required auto-close time		Gate closes
8. At closed position		Continuous beep
9. Dip-switch 2 off		Continuous beep stops
To change the pedestrian parameters again without leaving programming, repeat from point 2.		
Remove program jumper or continue to another programming option		

**Changing crawl distance:-**

Default: - 350mm

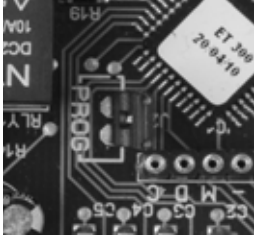
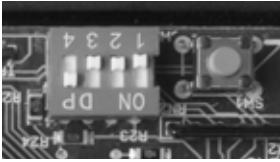
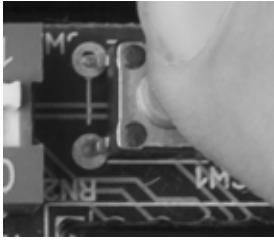
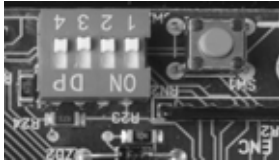
Action		Response
1. Program jumper on		2 beeps
2. Dip-switch 4 on		
3. Press and release Set button		Beeps confirm change 1 beep = 350mm 2 beeps = 700mm
		Continuous beep
4. Dip-switch 4 off		Continuous beep off
To change again without leaving programming, repeat from point 2.		
Remove program jumper or continue to another programming option		

**Changing switch type for safety beam input:-**

Default:- Normally open

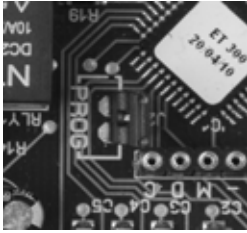
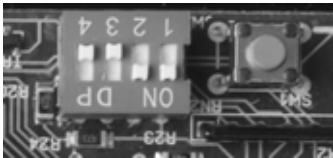
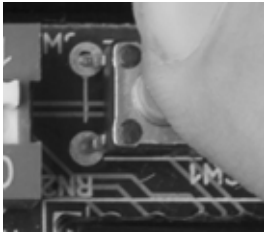
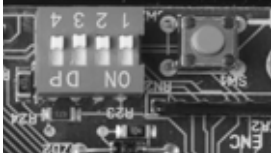
Action		Response
1. Program jumper on		2 beeps
2. Dip-switch 1 and 2 on		
3. Press and release Set button		Beeps confirm change 1 beep = N/C 2 beeps = N/O (Default)
After confirmation beeps		Continuous beep
4. Dip-switch 1 and 2 off		Continuous beep off
To change again without leaving programming, repeat from point 2.		
Remove program jumper or continue to another programming option		

**Adjusting safety obstruction sensing level:-**

Default: - 5KgF max resistance

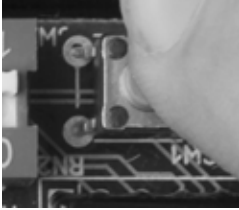
Action		Response
1. Rotate Load pot to new sensing level.		Clockwise = heavier gate resistance Anti-clockwise = lighter gate resistance
2. Press and release Set button to test level		Beeps confirm successful change 1 beep = 5kg resistance (Default) 2 beeps = 10kg resistance 3 beeps = 15kg resistance 4 beeps = 20kg resistance 5 beeps = 22kg resistance (max)
3. After audible confirmation.		Gate runs according to mode selected. (See operating mode selection on page 24)
Repeat if necessary.		
The load sensing level will also be confirmed audibly on any initial trigger after a full power up or manual release.		

**Collision/obstruction/hindrance while opening. (All modes)**

If a collision, obstruction or hindrance is encountered before the full open position is reached while opening, the gate will stop, back off and wait for the next trigger input, before closing slowly. The status LED will flash rapidly once stationery after backing off of collision. Closing trigger clears the status LED indication. For trigger responses see page mode selection on page 23.

**Collision/obstruction/hindrance while closing. (All modes)**

If a collision, obstruction or hindrance is encountered while closing, the gate will stop and reverse to the fully open position. The status LED will flash rapidly once stationery after opening away from the collision. The next trigger input starts the gate closing slowly. Closing trigger clears the status LED indication. For trigger responses see mode selection on page 24.

**Multiple collision/obstruction lock-outs. (All modes)**

On encountering 4 consecutive obstructions while closing the gate, the UMPETHA will not reverse back to the full open position. The response will be a 5 sec beep tone, followed by a gentle momentary reverse away from the obstruction. The unit will now begin a mandatory 30sec lockout whereby the only response to any trigger input will result in a tone so long as the trigger button is held. After 30sec a trigger input will result in a repeat of the 5 sec beep and the gate opening 1 meter or to the full open position whichever is reached first. The unit will once again lock out. This time the user must manual release the unit and test the travel by hand before attempting any further automation of the gate.

The Status LED will flash rapidly throughout this procedure indicating a multiple obstruction lock-out has occurred.





Releasing the gearbox and re-engaging it will clear the LED status and the multiple obstruction lock-out routine.

**Collision with closed stopper due to faulty or missing closed limit. (All modes)**



If no limit input is made when expected (as calculated by the programmed run time) the UMPETHA will not reverse back to the open position as it normally would when obstructed. It will however stop at the point of impact with the closed catch and emit a 5sec long beep tone. At the next valid opening trigger the UMPETHA will re-emit the 5sec long beep tone and only open the gate by ±1 meter. This will allow for the user to be able to enter the property and manually override the gate. The magnet actuator and limit can now be checked. If not corrected and further attempts are made to operate the UMPETHA with a faulty closed limit condition the same routine will be repeated on every operation.

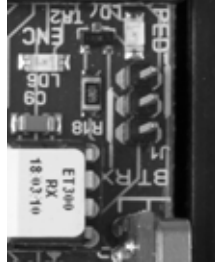

If the user continues to attempt to operate the gate without manually releasing the gearbox while the gate is at the ±1 meter position, the result will only be a repeat of the 5sec beep tone.

**Receiver programming: - Master erase;**

Action		Response
All power off		
Short both PED (pedestrian) and BT (full opening) pins to center pin (Use the key-ring supplied with the transmitters to do this as shown here)		
Power up		RX (receiver) LED flashes rapidly - stops flashing - on continuously.
Remove all power		
Remove RX (receiver) pins short		
Power up		RX (receiver) LED on

**Learning a TX (transmitter) button for BT (Full opening) operation using RX (receiver) pins: -  
(25 user memory)**

Action		Response
Press and hold required TX (transmitter) button		RX LED flickers
Short Center RX (receiver) pin to BT (full opening) pin (Furthest pin from the gate)		RX (receiver) LED flashes confirmation 1 flash = First transmitter learnt 2 flashes = Successful there is still memory available Multiple rapid flashes = memory full
Remove short after confirmation		RX (receiver) LED remains lit in standby





Action		Response
Press and hold required TX (transmitter) button		RX (receiver) LED flickers
Short Center RX (receiver) pin to PED (pedestrian) pin (Closest pin to the gate)		RX (receiver) LED flashes confirmation 1 flash = first transmitter learnt 2 flashes = Successful there is still memory available Multiple rapid flashes = memory full
Remove short after confirmation		RX (receiver) LED remains lit in standby
Release transmitter button		

**Learning a TX button for BT (Full opening) operation using the RX (receiver) Master remote: - (25 user memory)**

The RX (receiver) Master remote can only be learnt into memory using the RX (receiver) pins! The RX (receiver) Master remote is the first remote learnt into the BT (full opening) memory and it must be able to operate the PED (pedestrian) function of the built-in RX (receiver) as well.

Feature not available in Condo/loop mode

Feature limited to learning in BT (full opening) operation transmitters only.

Action		Response
1. Open gate fully using the RX (receiver) master remote		Gate runs to full open position and stops
2. Press and hold RX (receiver) Master remote pedestrian button.		Start of 5sec. Beep. Waiting for new remote trigger.
3. Release RX (receiver) Master remote pedestrian button		Continues to beep.
4. Press and hold required button on new TX (transmitter) before learn mode timer expires and beep stops.		Long beep changes to..... 2 beeps = Successful there is still memory available Multiple rapid beeps = memory full No beep = Button already in RX (receiver) memory or non ET Blue TX (transmitter) used.

To continue adding remotes repeat from point 2.

If no new TX (transmitter) button is pressed within 5 seconds of the continuous beep beginning, then the RX (receiver) will exit learn mode. All functions return to normal.

**Operating mode selection  
(Program jumper off)**

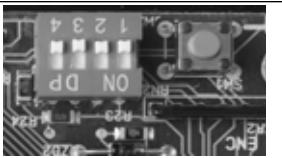

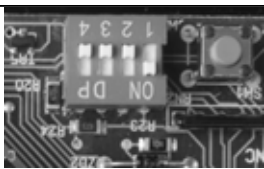
Dip-switch selection		Mode
<b>All off</b>		<b>Standard (Four step logic)</b>
<p>When the motor is activated using any BT (full opening) input the gate will open or close and can be stopped in mid cycle using any BT (full opening) input again.                      The gate can then be reversed by activating the BT (full opening) input again.                      In this mode the gate will remain open where it has been stopped either by button or open limit until the BT (full opening) input is activated again. (No auto close)</p> <p>Party mode is available in this mode. (See additional features below)                      Holiday lock out is available in this mode. (See additional features below)                      Master remote programming is available in this mode. (See page 23)</p>		

Dip-switch selection		Mode
<b>Dip-switch 1 ON (only)</b>		<b>Simple Auto-close</b>
<p>As per Standard mode above however the following differs: -</p> <p>The unit times out the pre-programmed auto-close time when stopped in any open position. Once the auto-close time has expired it begins closing the gate.                      While closing the gate any BT (full opening) or BM (beam) input will stop and reverse the motor direction back towards the full open position.                      In any open position while auto-close is timing out a BM (beam) input will reset the auto-close timer.</p> <p>Auto-close override/Party mode is available in this mode. (See additional features below)                      Holiday lock out is available in this mode. (See additional features below)                      Master remote programming is available in this mode. (See page 23)</p>		

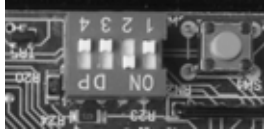

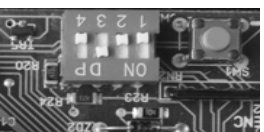

Dip-switch selection		Mode
Dip-switch 2 ON (only)		<b>Complex Auto-close/Condominium</b> (select when using a loop detector)
<p>In this mode <b>any</b> BT (full opening) input trigger is treated as an opening trigger. On reaching the full open position the unit times out the pre-programmed auto-close time after which it will begin closing the gate. If the BM (beam) or BT (full opening) input is activated while the auto-close timer is running the time will simply reset.</p> <p>On closing any BT (full opening) input or BM (beam) input will re-open the gate to the full open position.</p> <p>USE THIS MODE WHEN CONNECTING A LOOP DETECTOR.</p> <p>Auto-close override/Party mode is <b>NOT</b> available in this mode. (See additional features below)</p> <p>Holiday lock out is <b>NOT</b> available in this mode. (See additional features below)</p> <p>Master remote programming is <b>NOT</b> available in this mode. (See page 23)</p>		

Dip-switch selection		Mode
Dip-switch 3 ON (only)		<b>P.I.R.A.C. Auto-close</b> (Passive-infra-red access control)
<p>In this mode the unit will operate as per Simple auto-close above. The added feature here is quick closing once the BM (beam) input has been activated and cleared.</p> <p>I.e The gate is opening; a car enters the beams and passes right through. The BM (beam) input is now clear again and the gate immediately closes.</p> <p>If the gate reaches the full open position the pre-programmed auto-close timer times out after which the gate will begin closing.</p> <p><b>Except when used in conjunction with Complex auto-close mode.</b></p> <p>Auto-close override/Party mode is available in this mode. (See additional features below)</p> <p>Holiday lock out is available in this mode. (See additional features below)</p> <p>Master remote programming is available in this mode. (See page 23)</p>		

<b>Additional functions</b>		
<b>Holiday lock-out</b> Available in all but Complex Auto-close mode.		
<b>Action</b>		<b>Response</b>
1. Close gate		
2. Press and hold the PED (pedestrian) button on a master remote		Until 5sec beep begins.
3. Release PED (pedestrian) button on master remote		Beeping will continue until confirmation or 5sec expires.
4. Press and release BT (full opening) button on the master remote before 5sec beep stop.		1 x multiple rapid beeps will confirm holiday lock-out is active.
To unlock repeat		After multiple confirmation beeps gate will immediately start opening when unlocked.
<p>Holiday lock-out is available only when using a master remote. (No hardwired devices will activate)                      A master remote is a remote that has BT (full opening) control as well as PED (Pedestrian) opening control.                      If no BT (full opening) confirmation trigger is received by the time the intermittent beeps stop (5sec.), the gate will not change status.</p>		

<b>Beam tamper alarm output (BAO).</b> <b>Available in all modes.</b>
<p>The alarm output will trigger if the BM (Beam) input is activated continuously for <math>\geq 20</math>sec with the gate in the closed position. This output should be connected to an "ET relay on board" which in turn can be connected to a zone on the alarm system or simply a light that the user can easily see when approaching the gate. In this way the user can identify if someone has tampered with the beams, trying to prevent the gate from closing again once they have entered the property.</p>

<b>Auto-close override Party mode</b> Available in all but Complex Auto-close mode.		
Action		Response
1. With the gate at any open position		
2. Press and hold any TX (transmitter) BT (full opening) button		After 5sec unit will emit Multiple rapid beeps to confirm.
3. Release input after beeps		Gate will not begin closing after auto-close time has expired.
4. To deactivate repeat 2 and 3 above		1 x long beep and gate starts closing.
If any PED (Pedestrian) or BT (full opening) input is momentarily activated while the unit is in either Holiday lock-out or Auto-close override/Party mode the unit will only emit the multiple rapid beeps and not run the gate.		

<b>Pedestrian opening</b> Available in all modes.		
Action		Response
1. Gate in closed position		
2. Press and release any PED (pedestrian) input.		A) 3 x 1sec beeps after which gate opens to pedestrian opening position. B) At pedestrian opening position pedestrian auto-close timer times out. C) 3 x 1sec beeps after which gate re-closes.
Any further PED (pedestrian) input triggers while the gate is running are ignored except in the pedestrian opening position, where the auto-close timer will simply reset. Any BM (beam) input while the pedestrian routine is running will cause the gate to continue to the pedestrian opening position or reverse back to the pedestrian opening position. If already in the pedestrian opening position, the auto-close timer will simply reset. Any BT (full opening input while the pedestrian routine is running will open the gate to the full open position and the unit will revert to the operating mode selection that has been setup.		

<b>Courtesy light out</b> Available in all modes.
The courtesy light output will activate on any opening trigger (BT or Pedestrian). The light output will remain on until three minutes after the gate has re-closed.

**Buzzer indications overview**

Beeps	Gate status	Program Jumper	Action	Response Motor	Condition	Solution	Table ref.
5 x Rapid beeps	Full closed	Off	Momentary BT or Ped input	None	Holiday lock-out active	Toggle off	Pg 26
Continuous rapid beeps	Gate anywhere	On	None	None	Holiday lock-out active	Toggle off	Pg 26
5 x Rapid beeps	Gate anywhere but closed	Off	Momentary BT or Ped input	None	Auto-close override/party mode active	Toggle off	Pg 27
1 x 5sec beep (long beep)	opens 1m and remains there.	Off	Momentary BT or Ped input	None	limit failure	check magnet on gate and limit switch	Pg 20
2 x Rapid beeps	Gate anywhere	Off or On	Momentary BT or Ped input	Attempts to run	Battery flat or faulty	Allow recharge and check for Aux devices overload. If problem persists after ±8 hours charging, replace battery	
3 x 1sec. Beeps	Gate closed	Off	Momentary Ped	Gate opens partially	Pedestrian function activated		Pg 27
2 x 2sec. Beeps	Gate stopped	Off	Momentary BT	Gate runs	Household mains failure	Restore power supply	
10 x 1sec. Beeps	Gate stopped	On	Set button	None	No motor movement detected or beam input is active	Check beam circuit or setting. Check gate resistance.	Pg 19 & 20
1 x 5sec beep (long beep)	Gate stopped	Off	Any input triggered	None	Multiple collision lock-out	Check gate closing resistance	Pg 20

**Status LED overview**

Off	Gate closed
Slow flash	Gate is running or waiting for auto-close time to time out
On	Gate is open
Rapid Flash	Gate is obstructed or has exceeded max run time.

**WARRANTY:** All goods manufactured by G&C Electronics cc T/A ET Systems carry a 12 month factory warranty from date of invoice. All goods are warranted to be free of faulty components and manufacturing defects. Faulty goods will be repaired or replaced at the sole discretion of ET Systems free of charge. This warranty is subject to the goods being returned to the premises of ET Systems. The carriage of goods is for the customers account. This warranty is only valid if the correct installation and application of goods, as laid out in the applicable documentation accompanying said goods, is adhered to. All warranty claims must be accompanied by the original invoice. All claims made by the end user must be directed to their respective service provider/installer.

The following conditions will disqualify this product from the warranty as laid out above.

These conditions are non-negotiable.

- Any unauthorized non-manufacturer modifications to the product, components thereof.
  - Variations to the installation technique as laid out here-in
    - Incorrect application and use of the product.

The following are excluded or limited from the warranty as laid out above.

These conditions are non-negotiable.

- The battery carries a limited 6 month warranty
  - The motor brushes
  - Acceptable wear and tear.